

# KHARMA

## EXQUISITE COLLECTION

OWNER'S MANUAL

EXQ-MD-3.0

# SAFETY INSTRUCTIONS

## IMPORTANT SAFETY INSTRUCTIONS

### Warning!

TO REDUCE THE RISK OF FIRE OR ELECTRIC SHOCK, DO NOT EXPOSE THIS PRODUCT TO RAIN OR MOISTURE.



### CAUTION

RISK OF ELECTRIC SHOCK  
DO NOT OPEN



CAUTION: TO REDUCE THE RISK OF ELECTRIC SHOCK,  
DO NOT REMOVE ANY PART.  
NO USER-SERVICEABLE PARTS INSIDE.  
REFER SERVICING TO QUALIFIED SERVICE PERSONNEL.

### Important

The lightning flash with arrowhead symbol, within an equilateral triangle, is intended to alert the user of the presence of un-insulated << dangerous voltage >> within the product's enclosure that may be of sufficient magnitude to constitute a risk of electric shock to persons.

### Important

The exclamation point within an equilateral triangle is intended to alert the user to the presence of important operating and maintenance (servicing) instructions in the literature accompanying the product.

*Awaken your senses*

## CONGRATULATIONS

You are now a Kharma loudspeaker owner. Your new Exquisite Midi loudspeaker system, properly installed, will give you all the satisfaction and enjoyment you expect from Kharma. Technically at the fore-front of current audio equipment design, the Exquisite loudspeakers will reveal the full emotional range of music and will do so with vivid dynamics and detail. As with any high quality product, special care must be taken to install and operate your new loudspeakers.

Please read this manual carefully and totally prior to installation.

# TABLE OF CONTENTS

2	Safety Instructions
3	Congratulations
5	Introduction the Exquisite Midi
6	Part list
7	Unpacking
11	Connection
12	Positioning your speakers
13	Using your speakers
14	Taking care of your speakers
15	Specifications
16	Warranty

# INTRODUCTION TO THE EXQUISITE MIDI

## **Diamond concave tweeter**

The diamond tweeter that is used in the Exquisite series is a true technological wonder. The tweeter has a diamond cone which has been realized by the so called CVD process. With this process incredible stiffness is reached with a minimum of thickness of only 50  $\mu\text{m}$ . Notice a human hair is in the range of 17 to 180  $\mu\text{m}$ . The cone is the most essential part of the tweeter and because this cone is made of Diamond the tweeter is capable to create impressively pure high frequencies.

## **Kharma Omega 7 driver**

The midrange of this speaker is formed by our in-house developed Kharma Omega 7 driver, where the number is referring to the 7-inch size of this carbon based driver. The new cone technology used for the Omega 7 driver is based on Ultra High Modulus carbon fibers, which is the best fiber available on the globe today. The use of these ultra-stiff carbon fibers and an unique resin displaces the break-up frequencies of the cone, in comparison with a standard cone material, to a whole other level. These

increased break-up frequencies ensures the cone is free from almost all resonances in the intended frequency range for this midrange driver. Moreover, the cone shape is optimized with a finite element analysis to utilize the full potential of the carbon material. This combination of the best carbon fiber and an optimized cone shape has resulted in a near perfect behavior for the Kharma Omega 7 driver.

## **Nomex-Kevlar driver**

The woofers have 8 inch sandwich-honeycomb-Kevlar cones which also again are completely free from structure born resonances in the used frequency range.

## **Cabinet**

The cabinet of the Midi Exquisite is constructed of thick high pressure laminate.

## **Crossover**

This Exquisite loudspeaker can only achieve astonishing musicality by using complex crossover techniques, which can be seen as the beating heart of this loud speaker.

This complex in-house developed crossover will lead all drivers to the right music composition. Therefore the crossover can be seen as an orchestra conductor, which will have to turn the information received through the loudspeaker cable into a musical spectacle as if it was read from a music sheet.

Kharma has mastered the art of retaining musical wholeness with the proprietary crossover technique used throughout the Exquisite series. This technique is seldom used by other manufacturers because of its complexity. This results in a Kharma crossover where there is simply no gap in information.

## **Stand**

Mechanical residual vibrations of the cabinet are terminated by the Spike Disk Suspension System (SDSS) by minimizing the contact area between the cabinet and the floor. The SDSS stand also provides a fixed and levelled orientation for the cabinet drivers, because each spike can be adjusted individually in the vertical direction.

# PART LIST

## The two crates will contain

- 2x Exquisite Midi Loudspeaker
- 8x felt pad
- 2x Tweeter ring
- 1x Kharma key
  
- Manual
- Burn-in CD
- Registration form
- Quality certificate
- Certificate of Authenticity

### Important

Please read the manual thoroughly before taking further steps.

# UNPACKING

## Opening the box

Upon opening the box, inspect the box carefully for any sign of transport damage. If there is damage, immediately call your dealer or the trucking firm that made the delivery. Do not delay in reporting the damage. Please store the crates for future use

## Step 1: remove the top cover and side panel

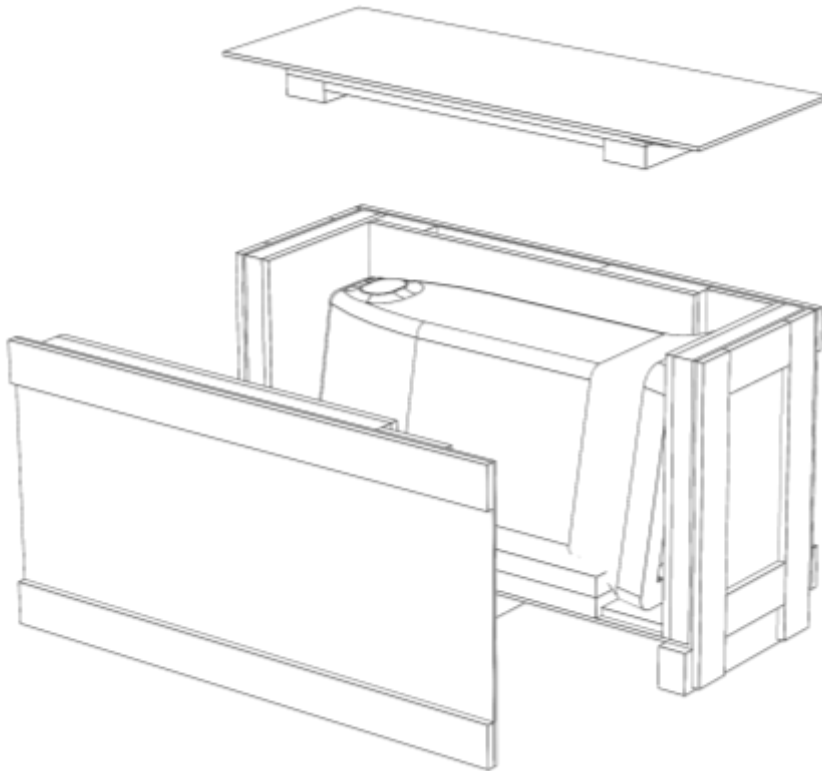

In the side pocket of the foam, you will find a leather box.

Inside the box you will find all documents, the tweeters rings and the Kharma key.

## Step 2: lift out the speaker

Carefully take out the speaker, you can use the side panel to place the speaker on.

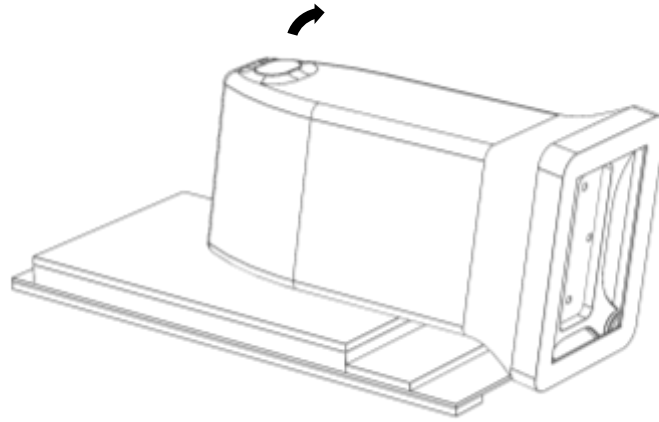

If you have hard flooring you can stick the felt pads to the bottom of the spike disc.

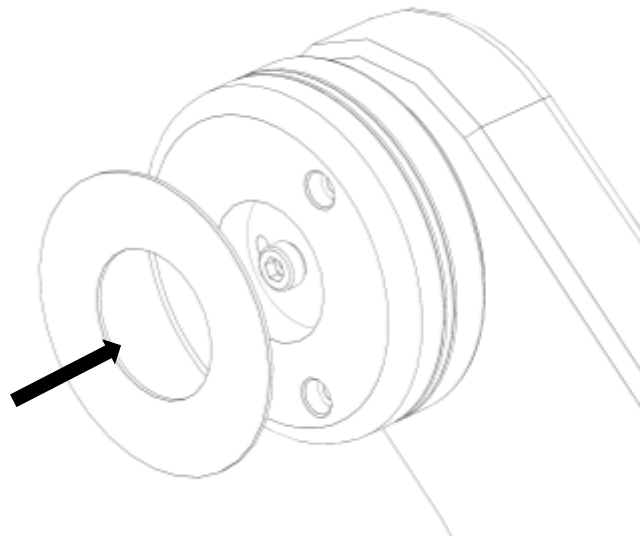

Then tilt the speaker in upwards position



### Step 3: positioning the speaker

You can now remove the protective cloth from the speaker. Please store the bag for future use.

Move the speakers to required position.

To level the speaker use the supplied hex key.

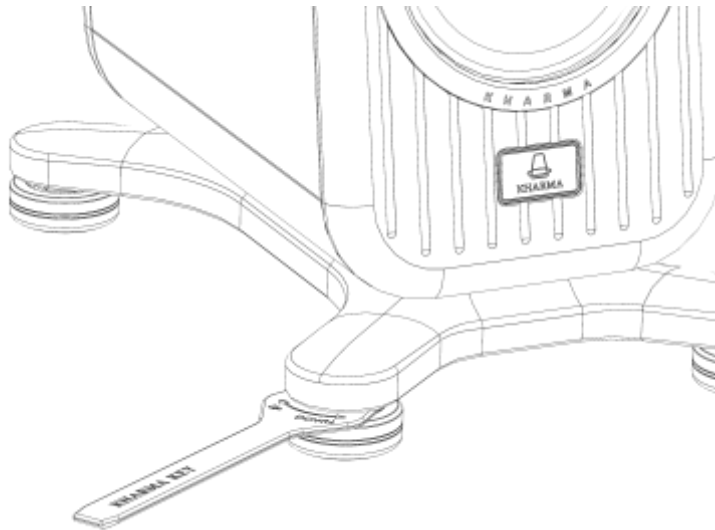

Turn the key clockwise to lift the feet or counter clockwise to lower the feet. You can safely lift the feet approximately 15mm. Be sure not to lift it more, this might cause the spike system to come loose from the stand.

#### Step 4: removing the tweeter protector

When your speaker is properly leveled you can remove the tweeter protection cap. Turn the screws counterclockwise to release the cap.



The decorative rings use magnets to fix on the tweeter face plate. Please use caution when fixing the decorative ring, diamond tweeters are very fragile.

# CONNECTION

At the rear of your Exquisite loudspeaker you will find the high-end Kharma Connection Terminal. Be sure you use the same brand, type and length of speaker cable on each channel.

Mixing different types and/or lengths of speaker cable can upset the precise timing and balance of your speaker.

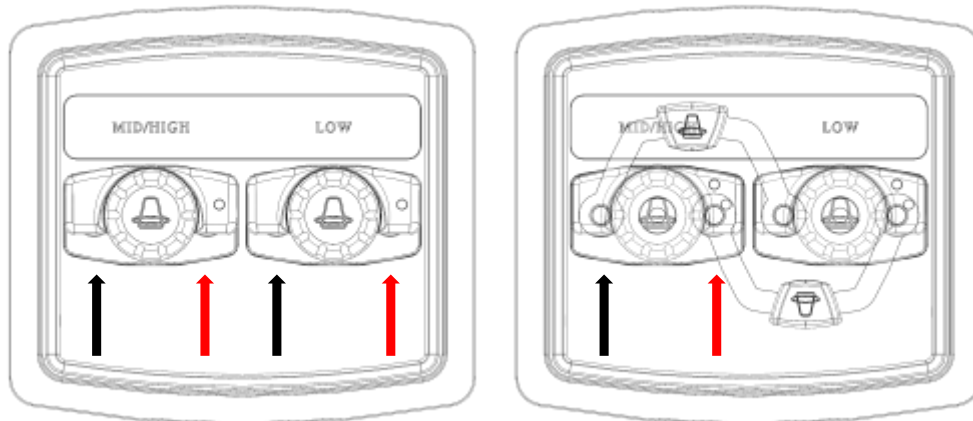

It's important to connect your speakers in phase, which means that the drivers are moving in and out in the same direction and at the same time, in order to obtain the best localization of instruments and voices as well as the deepest, most natural bass.

Always turn off the power of your entire system before making connections to your speakers.

## Important

You will find a short wire fixed to the connection terminal. This wire is fixed to protect the speaker drivers during transport, make sure to remove this wire before installing your cables.

The Exquisite Midi is advised to be used with bi-amping or bi-wiring. The left connector drives the mid and high drivers of the speaker and the right connector drives the bass drivers.

When you choose to setup your system with only one set of loudspeaker cables, you will have to install the Kharma bridge terminals as indicated in the picture on the right. For best sound quality we advise to connect the cable to the mid/high connector.

# POSITIONING YOUR SPEAKERS

## Room Acoustics

A good listening room has just the right amount of reflection and absorption. The performance of any loudspeaker depends upon the speaker's location in the room and the acoustical conditions in that part of the room. Furnishing, size and proportions all effect tonal balance, imaging and bass characteristics.

In order to test the sonic balance of your room, stand in the location where the loudspeaker will be installed and clap your hands two or three times. If the room is reverberant, you will hear a sharpness or echo. If the room is dull, the sound of the clap will decay rapidly and there will be little or no echo. Large areas of glass, mirrors and wood-paneling will reflect sound waves and often result in brittleness and extreme brightness.

You can correct this by breaking these sound-waves with softer surfaces; for instance, draperies or wall hangings. In general try to create random reflections.

## Positioning

We recommend experimenting with loudspeaker placement in order to obtain the best spectral balance, openness and perception of depth. For good results, the loudspeakers should be no closer than 45 cm from the rear wall with at least 70 cm to the side walls. The space between the loudspeakers should be free. Ideally the space should be symmetrical in the area around your loudspeakers.

Moving the system towards a wall will increase bass level while generally reducing openness. Moving loudspeakers too far into the room can result in a "thin" overall presentation with loss of bass foundation. The loudspeakers will normally work well straight out and not angled toward the listener for accurate sound staging. The wide dispersion of the Exquisite loudspeaker makes this possible.

It is easier to carry out room changes before installing the cone feet which thread into the base.

Many have found the best room position to be along an undraped longer wall, with the loudspeakers as far apart as the listener is for them. The stand under your Exquisite loudspeaker can be adjusted so that the speaker will not "rock" as you push it from side to side.

# USING YOUR SPEAKERS

## **Advice on cabling**

All loudspeakers in the Exquisite range are known for their uncompromised design to the finest detail. For this reason there can only be put justice to the quality of the Exquisite loudspeakers, when the used external cable is also uncompromised to the highest level. Therefore the use of the Exquisite cable series - which was especially designed to match the Exquisite loudspeakers – is strongly recommended to complement the sound of the Exquisite loudspeakers.

First of all we use in our external cables the same quality conductors and isolators as internal. So you get a sonic match. Furthermore an important reason for using these cables is that you will get exactly the sound that the Kharma team had in mind during the development of both the loudspeaker and the cables.

For the true connoisseurs of musical art, Kharma offers the possibility to even go one step further by complementing their Exquisite Loudspeaker with the Enigma Veyron cable series.

## **Advice on amplifier**

The recommend amplifier for the Exquisite is one of the mono power amplifiers of the Kharma MP1000 Series. There are several reasons why we recommend an amplifier of the MP1000 Series as amplifier for the Exquisite.

First of all it has sufficient power to drive the Exquisite loudspeakers to their full capacity, allowing you to drive the system in both small

and large spaces. The amplifiers of the MP1000 Series have an almost infinite damping factor which allows a very well controlled bass, which is why even a large Exquisite loudspeaker can be used in a limited sized room and still fulfil all audiophile wishes. A tube based power amp would create too much base in a small room.

The second reason is that the system has been voiced in with the amplifiers of the MP1000 Series during many listening sections. Although during development we use several top quality brands as amplifiers to drive our loudspeakers, we optimize the sound of Kharma with our own amplifiers. This will result in a system which exactly performs like we want it to.

## **Use common sense**

If you hear distortion or loud “cracking” sounds, the amplifier or loudspeaker is being overdriven, turn the volume down immediately.

## **Burn-in**

Your Exquisite loudspeaker system needs quite a bit of playing time to reach maximum result. The use of a Burn-in test-CD is recommended to speed up this process. With a “burn-in” test CD, burning time is reduced to approximately 50 hours. After burning-in your system, you can play demagnetizing tracks for maximum clarity. Your system will then be optimized and sound more open, more detailed and display more natural musical warmth.

# TAKING CARE OF YOUR SPEAKERS

Use a soft cloth and a spray-cleaner to clean the surface. Be careful not to spray on the grill cloth. Use a slightly wetted piece of foam to gently rub the cloth of the front panel. No further care is necessary.

In event of trouble Note that you can use your amplifier's two channels of information for simple troubleshooting.

If the sound quality is distorted, listen to each speaker separately to check if the fault is present in both. If it is, then the trouble is likely to be elsewhere in your system. If the fault is in one channel only, reverse the outputs from your amplifier to the speakers(right-to-left and left-to-right). If the distortion moves to the other channel, the fault is not the speaker. This technique may also be used to locate a fault between the signal source and preamp/receiver

and/or between preamp and power amp(s).

If you have been unsuccessful in locating the specific source of trouble or if you have located it, but have been unable to correct it, please consult the Authorized Karma-dealer from whom you purchased the system. Karma Dealers are audio specialists and can be of great assistance.

## Important

Do not attempt to repair the loudspeakers yourself. This will void the warranty on the product

# SPECIFICATIONS

## EXQUISITE MIDI

<b>System</b>	4-way
<b>High Driver</b>	1x 1 inch Diamond concave tweeter
<b>Mid Driver</b>	1x 7 inch Kharma Omega 7 driver
<b>Bass Driver</b>	2x 8 inch Nomex Kevlar driver
<b>RMS power</b>	250 Watt
<b>Program power</b>	400 Watt
<b>Freq. Range</b>	23 Hz - 90 kHz
<b>Efficiency</b>	90 dB
<b>Maximum SPL</b>	113 dB
<b>Impedance</b>	4 Ohm

### Dimensions

<b>Height</b>	1030 mm / 40.6 inch
<b>Width</b>	390 mm / 15.4 inch
<b>Depth</b>	645 mm / 25.4 inch

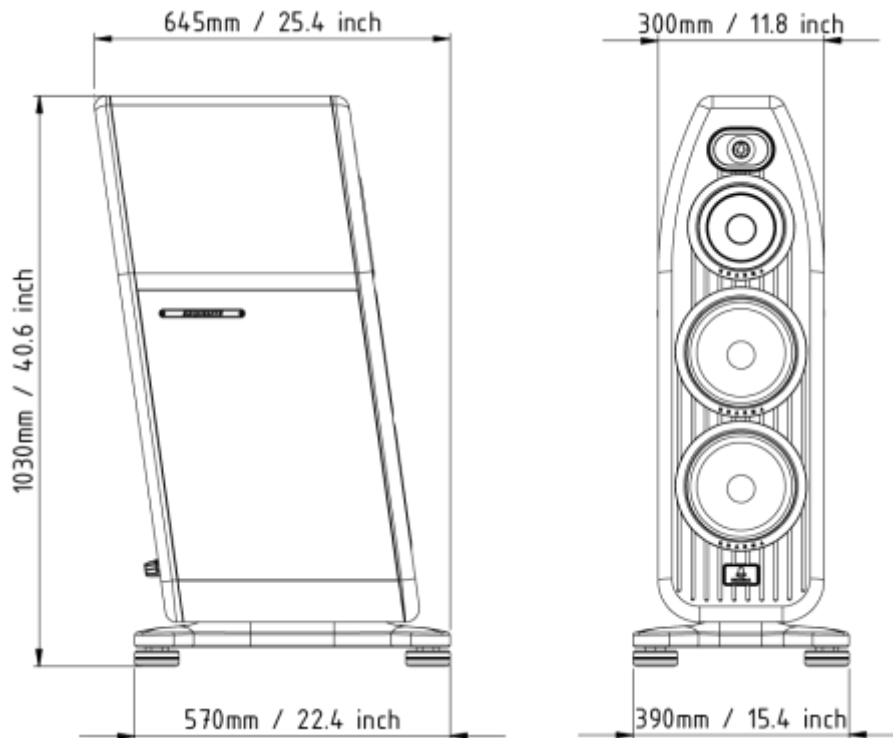

# WARRANTY

## Warranty coverage

The Kharma distributor guarantees the proper mechanical and electrical functioning of its products for a period of 5 years. Provided the warranty request card is properly filled out and sent to the address on the warranty form, including a copy of the original bill of sales. Should the customer fail to meet the three requirements mentioned above, the warranty will be limited to a period as required by national law only.

In case of malfunction the customer has to present the Kharma product in its original packing to an authorized dealer. If qualified service appears inevitable, the dealer will ship the product to an appointed service station or to the factory, depending on the required service. This warranty includes parts and labor. This warranty is not automatically transferable; subsequent owners can request a warranty at the factory.

## Warranty exclusion

1. Transportation damage, visible or hidden. Damage should be reported immediately to the transport company. Registration of the complaint should be sent to the Kharma distributor previously mentioned.
2. Scratches in painted and metal surfaces. Complaints should be registered at the dealer within three days after the sale.
3. Damage due to illicit handling and inappropriate use.
4. Transportation costs to service station or factory.
5. Damage through unauthorized repair and or modification.
6. Subsequent damage to other appliances.
7. Refund of costs in case of unauthorized repair.
8. Malfunctions caused by use for commercial of professional purposes.
9. All claims on Kharma products obtained through unauthorized sources, with or without correct serial numbers.