

ELEGANCE dB11-S

Loudspeaker system



Elegance dB11-S

Description

The Elegance collection is succeeding the very successful Ceramique line of high-end loudspeakers from Kharma. The Ceramique loudspeaker line was introduced in 1998 and the use of Ceramique-based drivers was the reason for naming this series like we did.

In the world of standard dynamic loudspeakers the dB11-S presents a never before achieved level of excellence in performance and design and a synergy in acoustical, electro-mechanical and aesthetical design. Multidisciplinary engineering on avoiding structure born and non-structure born resonances supporting the holy grail of unrevealing complex musical sound scapes and reproducing them, all in a compact nice aesthetical design to bring pleasure for many years to the user.

Innovation Award

Kharma is very proud to present the new Elegance dB11-S, which has been rewarded with the CES Innovations Award of 2014. The new speaker was judged upon different fields of engineering, aesthetic design qualities, user's value and of course it's innovative element. The dB11-S is judged by a pre-eminent panel of independent industrial designers, independent engineers and members of the trade media to honour outstanding design and engineering in cutting edge consumer electronics products across 29 product categories.



**THE NEW KHARMA
ELEGANCE DB11-S**

The Elegance dB11-S is build with the new KBPL cabinet technology, which increases the performance enormous. You are more than welcome to hear the Elegance on the CES 2014 - Las Vegas.

 The Kharma Elegance dB11-S has been rewarded with the 2014 Innovation Award.

 Visit us at the CES 2014
January 7-10, 2014
The Venetian - level 29 - room 334

Features

The shape of perfection

The new cabinet of the dB11-S is made partially of Kharma Bullet Proof Laminate (specific density > 1,25g/cm³). This material is a very high pressure laminate treated with a special coating. The KBPL increases rigidity compared to techniques used in the past, while the coating and dampening eliminates the last traces of resonance. The Kharma Elegance dB11-S presents the ultimate synergy in sound reproduction with dynamic transducers. Each part of the design constitutes the maximum possible at current times.

The acoustically perfect shape of cabinet with polygone slanted, angled baffle supports seamless transitions in the crossover regions between the drivers and off-axis group delay behavior. Result is that the reflections of sidewalls in the room are more phases coherent and build up more realistic 3D imaging with the direct perceived.

Living music

One of the many redesigned parts of the Elegance is the grill of the dB11-S. This new improved grill is made detachable by embedded magnets to really have the freedom to adapt the Elegance dB11-S to your own style. With grill the Elegance gives an elegant and luxury feeling, where the dB11-S without grill shows the beauty of the new composite drivers without actual showing that a grill could be attached.

Trimmable rings

The Elegance dB11-S has the new special feature of trimmable luxury rings around the drivers, which hide the mechanical screws of the driver. The unique feature is that the rings are made magnetic and so can easily be interchanged with other versions of the trimmable rings.

Connectors

The Elegance dB11-S has Kharma Bi-Wire terminals executed with the Kharma Binding Post system for the Elegance (KBPS-EL)

Internal cabling

Very few loudspeakers can actually boast of pure silver internal wiring because of the high cost of the silver. Though, the Elegance dB11-S is fully loaded with ultra pure silver, which provides endless detail over the whole frequency range.

Stand

A new Spike Disk Suspension System stand (SDSS-stand) has especially been developed for the Elegance series. This beautiful new stand is made of composite material with a shiny black finish, which is accentuated by a chrome disk and top cover.

Drivers

- High-frequency: 1 x 1-inch True Beryllium tweeter
- Mid-frequency: 1 x 7-inch Kharma Omega 7 driver
- Low-frequency: 2 x 10-inch Aluminium woofer

The midrange of this speaker is formed by our in-house developed Kharma Omega 7 driver, where the number is referring to the 7-inch size of this carbon based driver. The new cone technology used for the Omega 7 driver is based on Ultra High Modulus carbon fibres, which is the best fibre available on the globe today. The use of these ultra stiff carbon fibres and an unique resin displaces the break-up frequencies of the cone, in comparison with a standard cone material, to a whole other level. These increased break-up frequencies ensures the cone is free from almost all resonances in the intended frequency range for this midrange driver. Moreover, the cone shape is optimized with a finite element analysis to utilize the full potential of the carbon material. This combination of the best carbon fibre and an optimized cone shape has resulted in a near perfect behaviour for the Kharma Omega 7 driver.

The effect of this innovation combined with the new development of a pure Beryllium tweeter is very clearly audible in even a short listening session. Ultra high resolution in the midrange depicting many layers and sound colours like in excellent wines, where the complexity of the whole history of making the wine, can be tasted in a moment. It is like the music is coming from an inner space with an infinite number of layering. No mp3 allowed please, give full credit to these wonders

Technical specifications

All new innovations and ideas have resulted in the technical specifications as given below. However, these specifications are still subject to changes, but will give a good indication till further notice.

Type:	EL-dB11-S-1.0
System:	3-way
RMS power:	380 Watt
Program power:	760 Watt
Frequency range:	21 Hz – 30 kHz
Nominal impedance:	4 Ohm
Efficiency 2.83V/1m:	89 dB
Maximum SPL:	115 dB



Dimensions

The dimensions of the Elegance dB11-S is in line with the performance it can deliver.

Including stand

Width: 469 mm / 18.5 inch
Height: 1288 mm / 50.7 inch
Depth: 794 mm / 31.3 inch

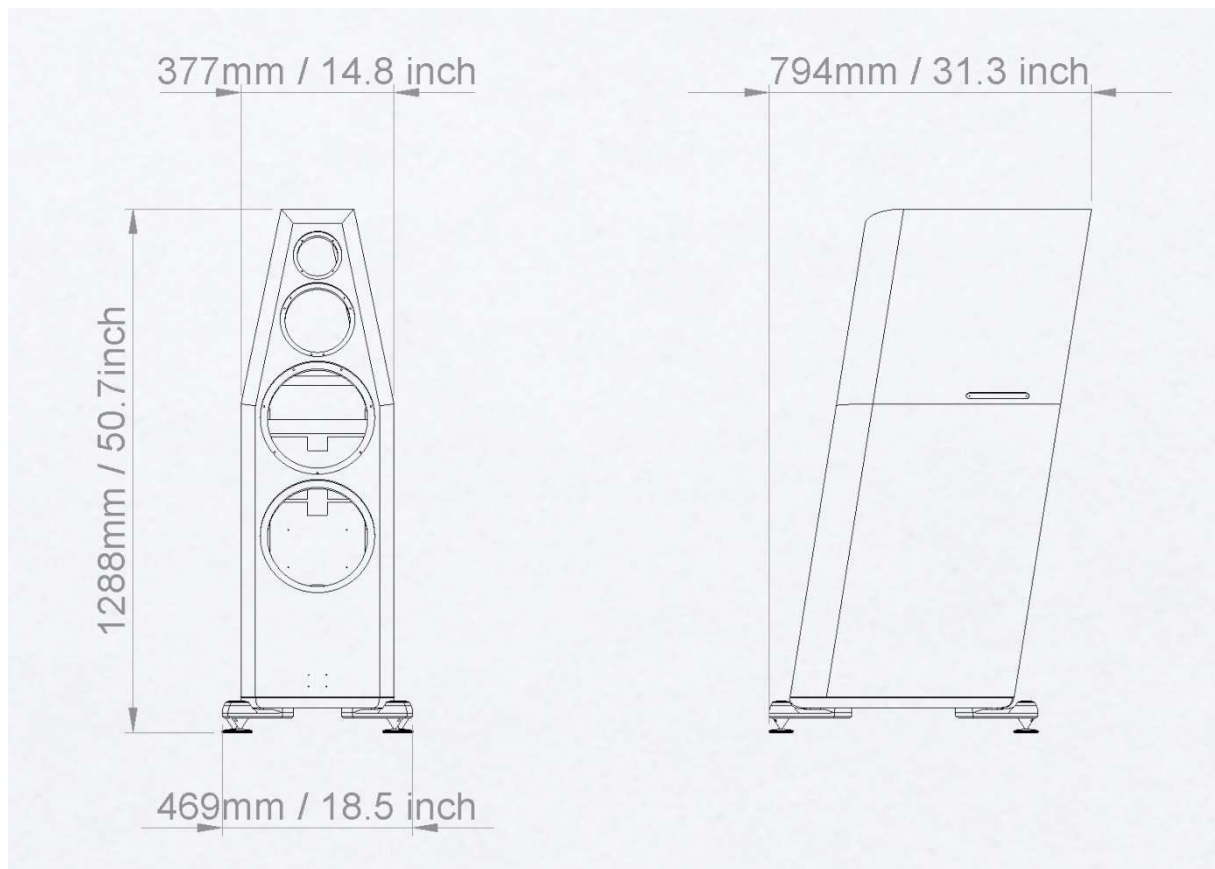

Product Program Structure

A Kharma product must not only have an unbelievable refined sound, which meets the needs of a true music lover, but also must have an astonishing finish to compete with the musicality of the system. As known by Kharma, every customer can have a taste of its own. Therefore Kharma developed two programs to be able to fulfil all levels of customization.

Primary Stock Program

This program has been targeted as to create the shortest possible delivery time for the official Kharma products. This program is therefore based on the most popular Kharma finishes, which have proven their looks in the past by many successful sales. In this way we can deliver both the high refined sound as the astonishing finish that can be expected from Kharma.

Primary Stock Program - Cabinet colours *:



Kharma Optionary Program

The visual tuning in the Optionary Program will give the customer the opportunity to choose between special selected Kharma colours. These colours have a higher level of customization and therefore the delivery time will be slightly longer than a Stock Program colour. There is only extra charge for the indicated special colour in this program.

Kharma Optionary Program - Cabinet colours *:



* Colours shown only give an indication of the real paint colour, contact your dealer for references.